



Nothing but **HEAVY DUTY.**<sup>®</sup>



# M12 BLPDRC

---

Original instructions

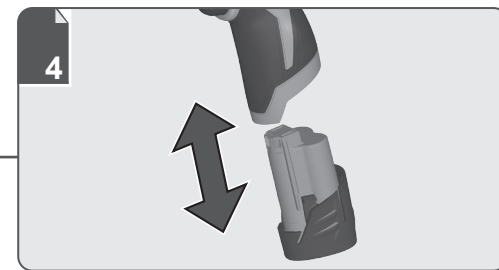
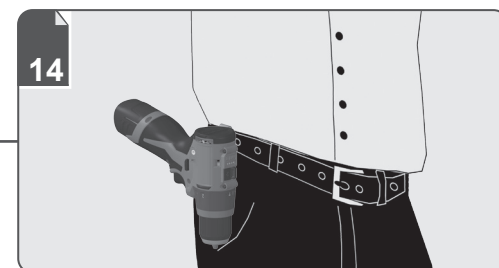
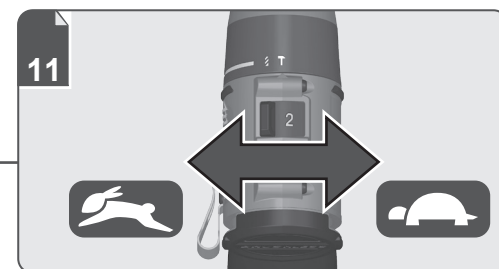
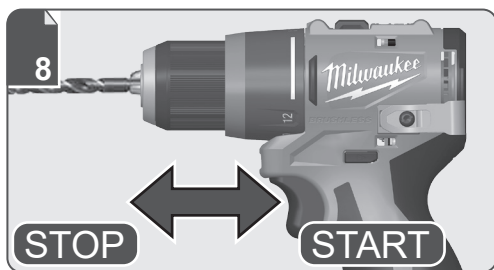
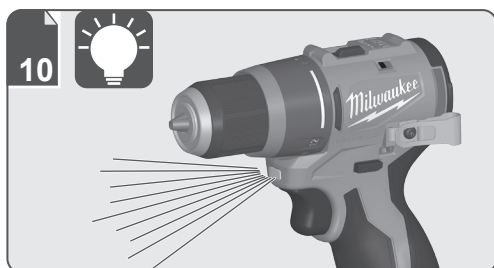
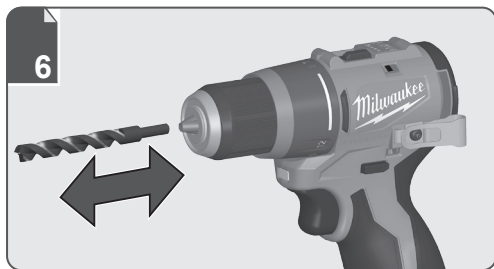
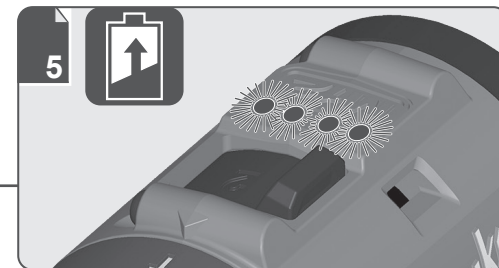
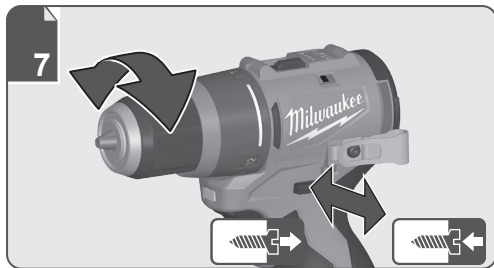

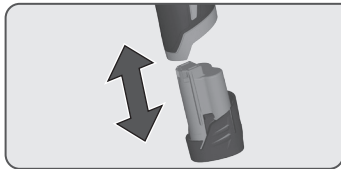

Remove the battery pack before starting any work on the product.

1

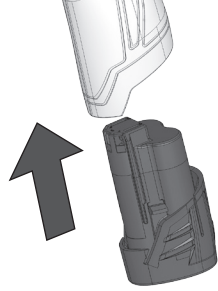

2



1

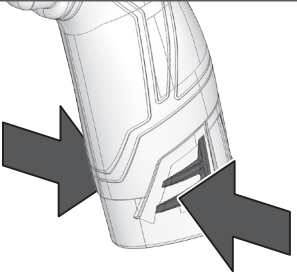

2

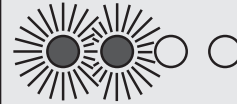
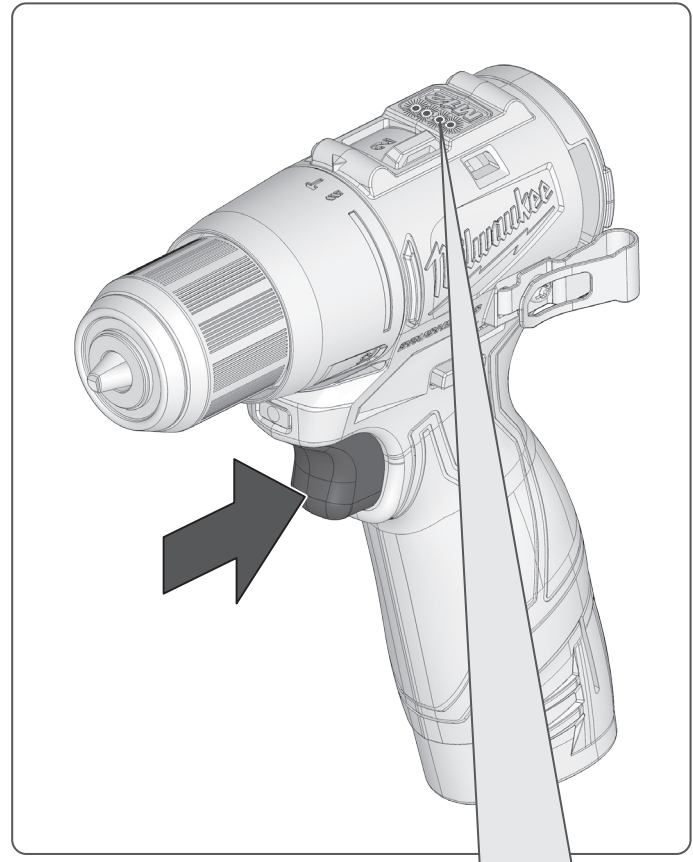
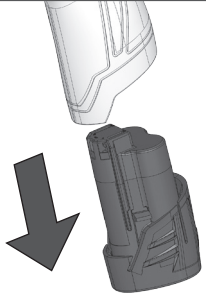

100%



75%



50%



25%

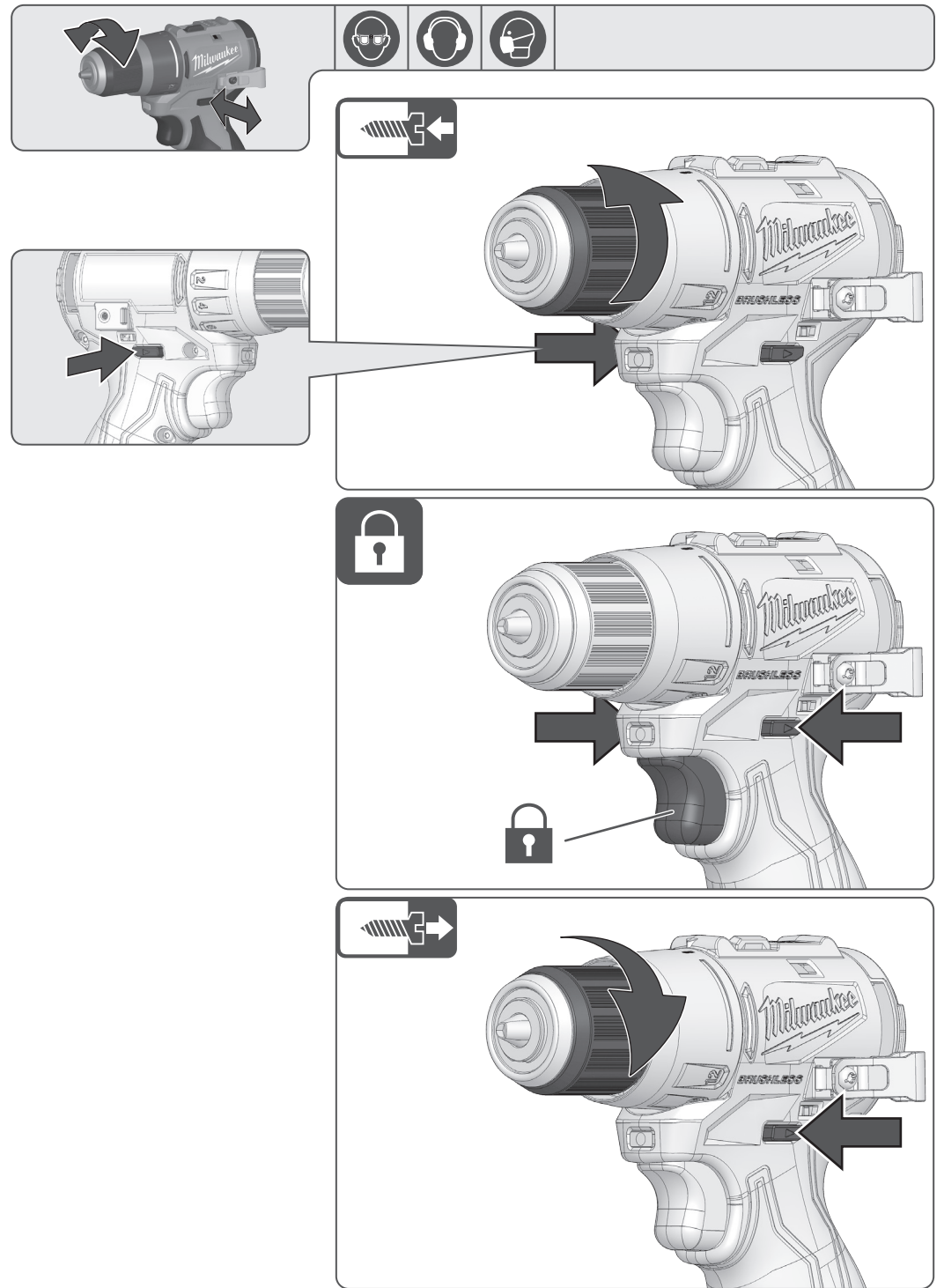
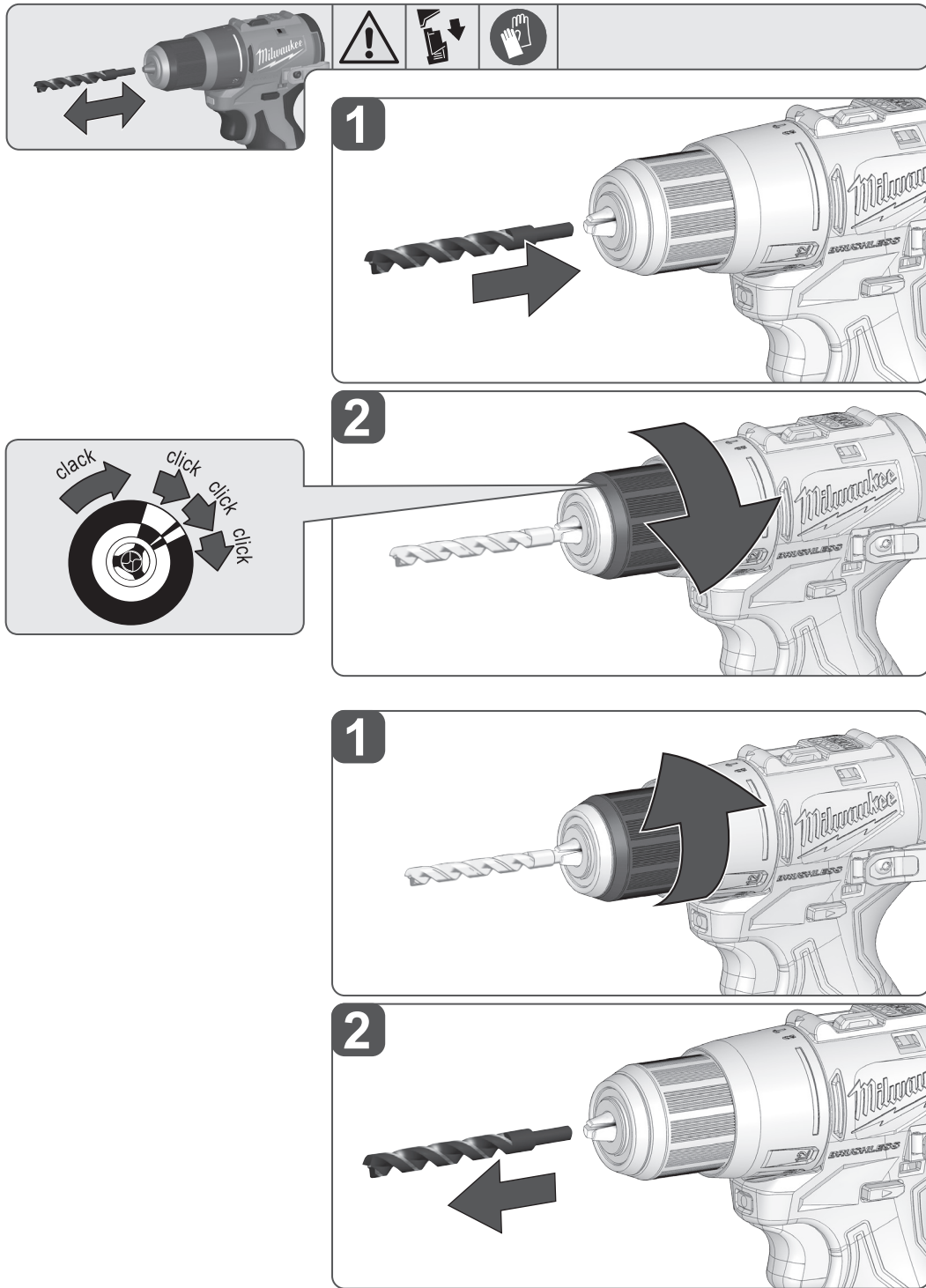



## START

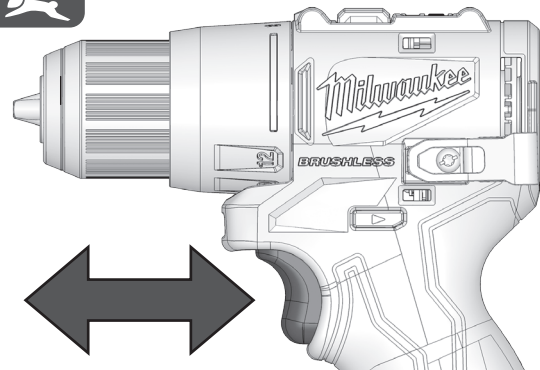
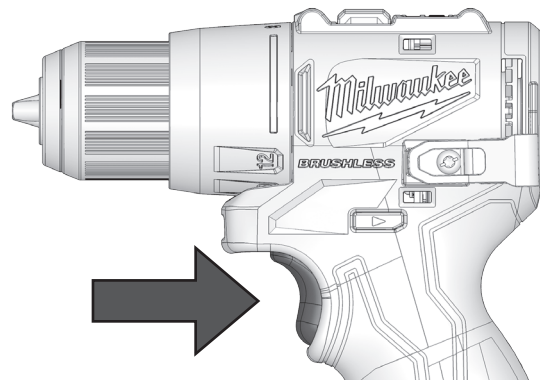

## STOP

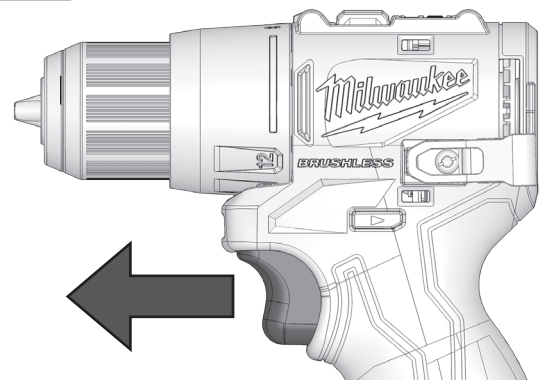

Insulated gripping surface

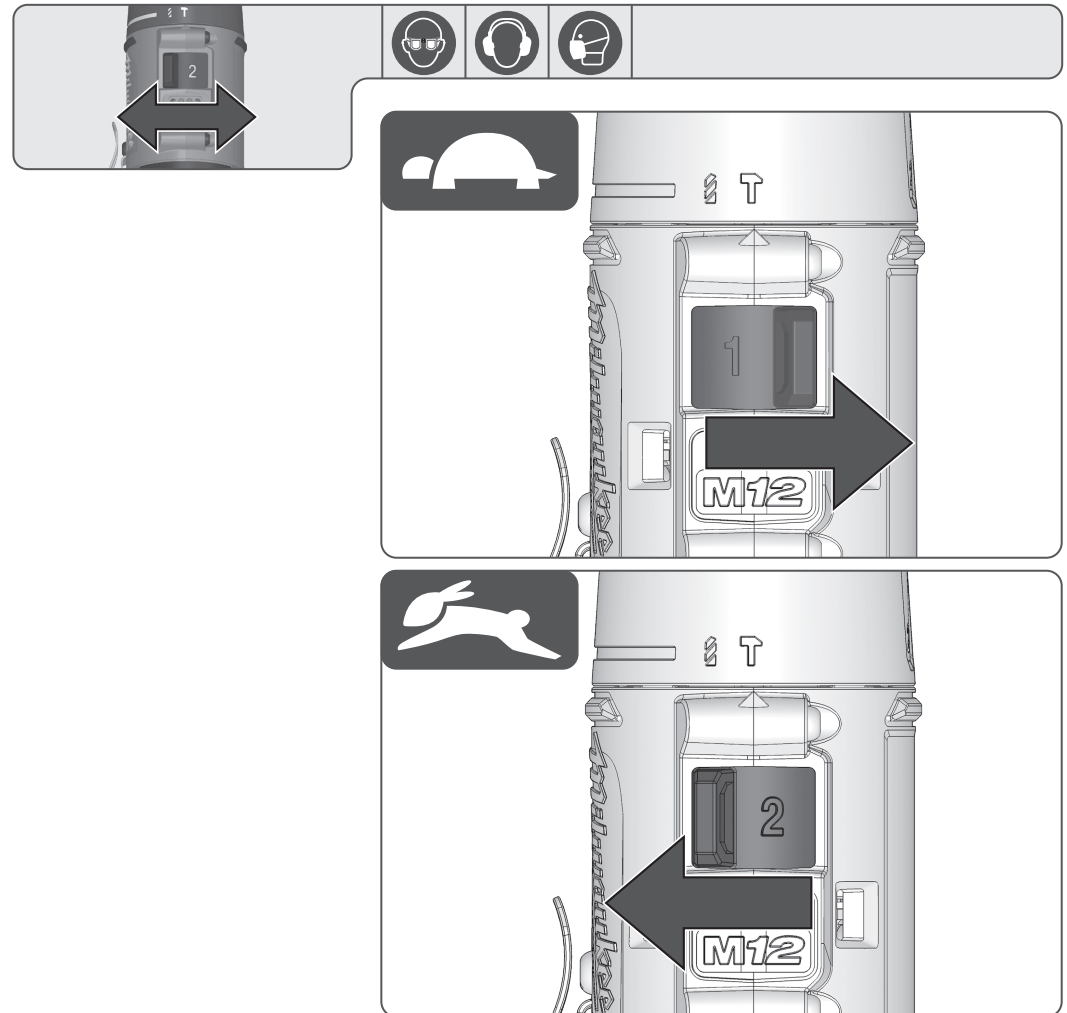
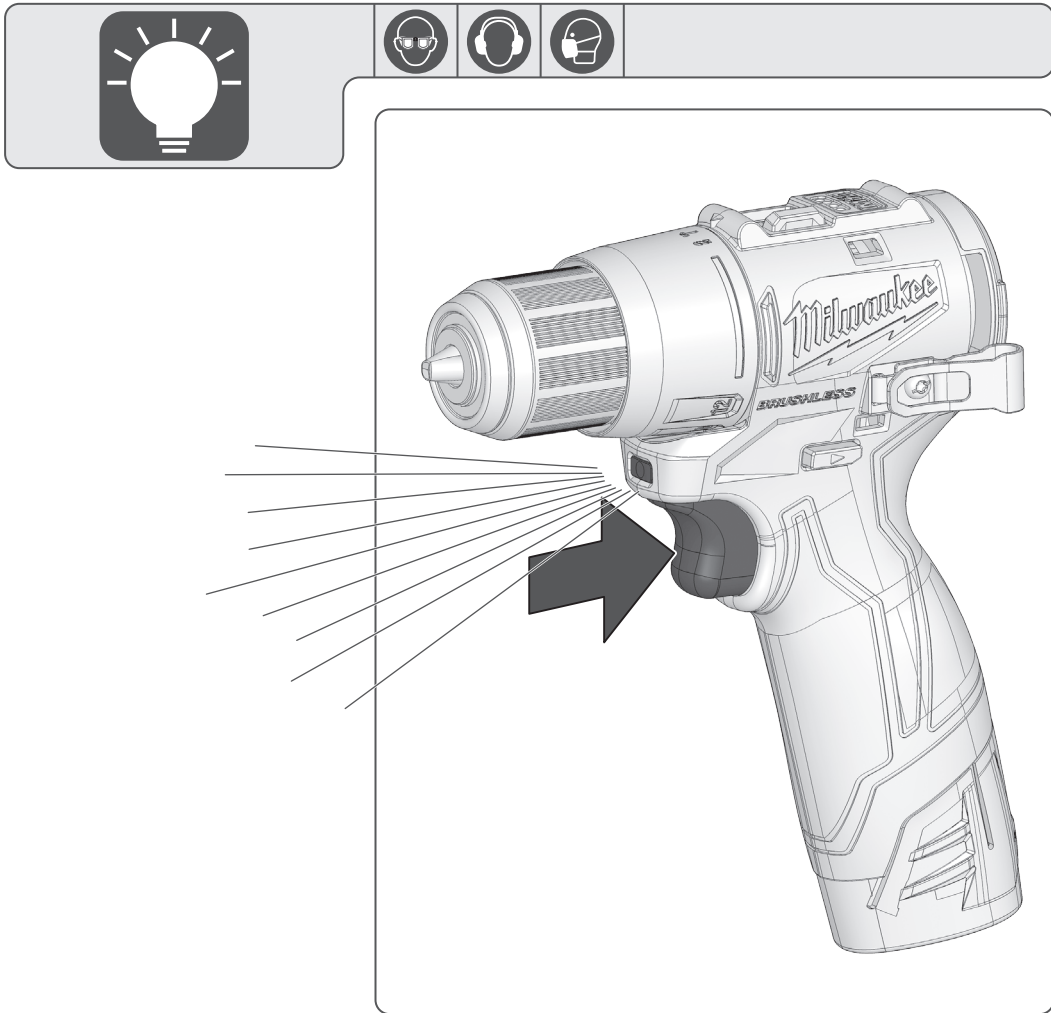

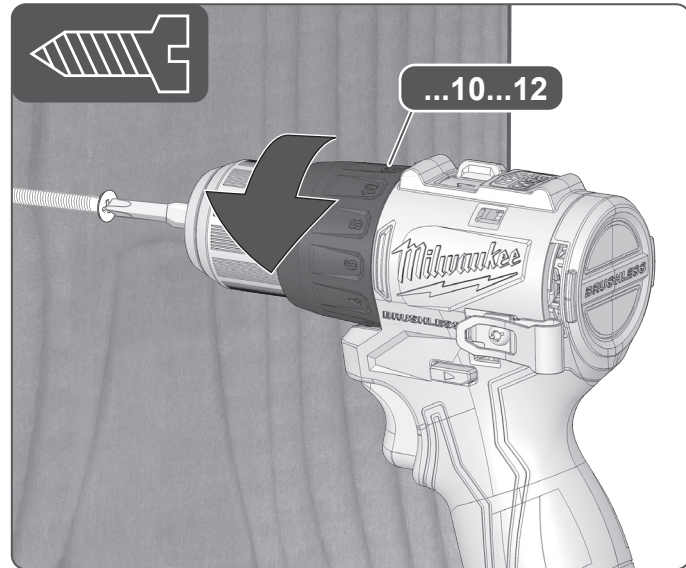
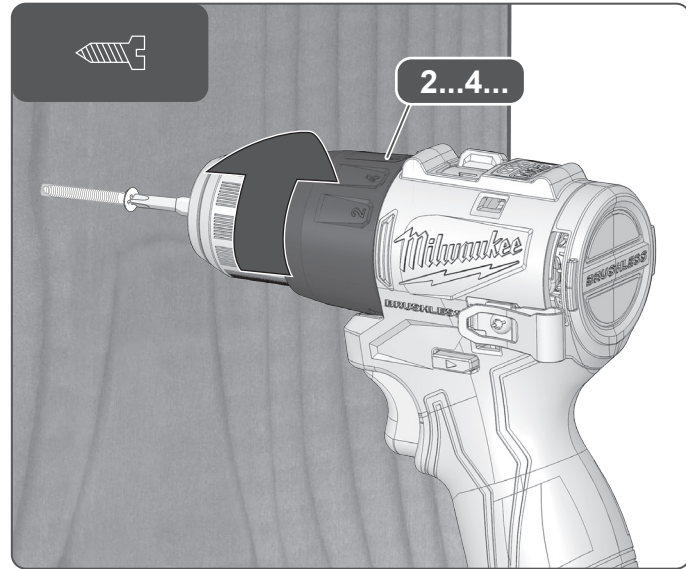
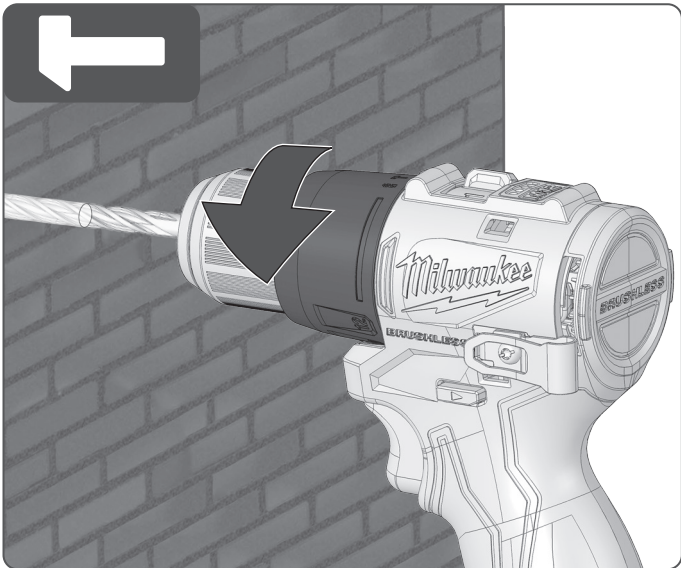
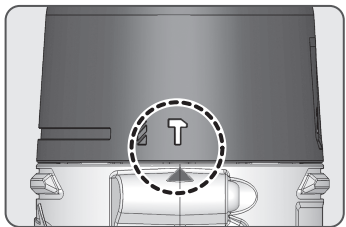
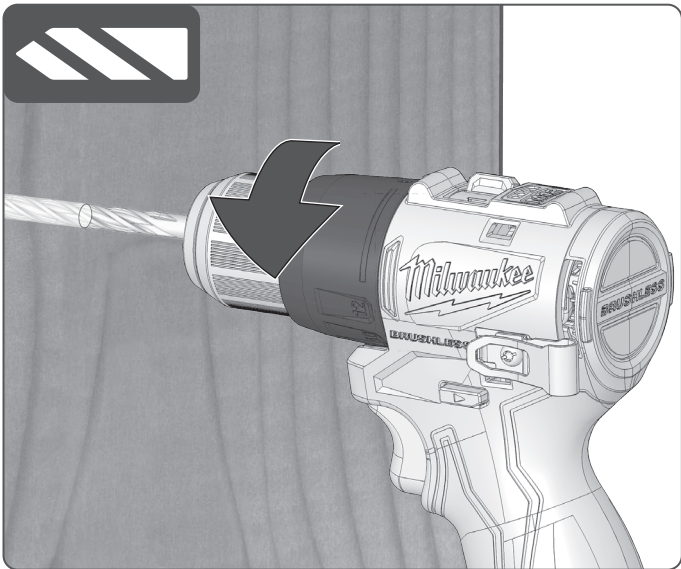
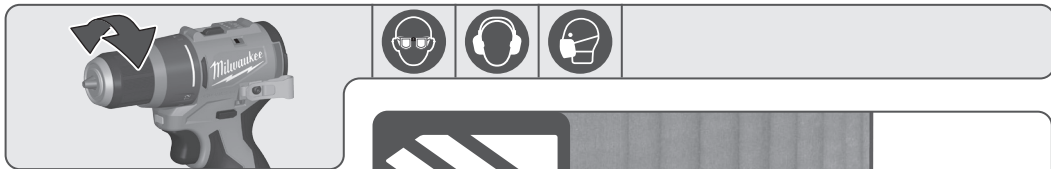

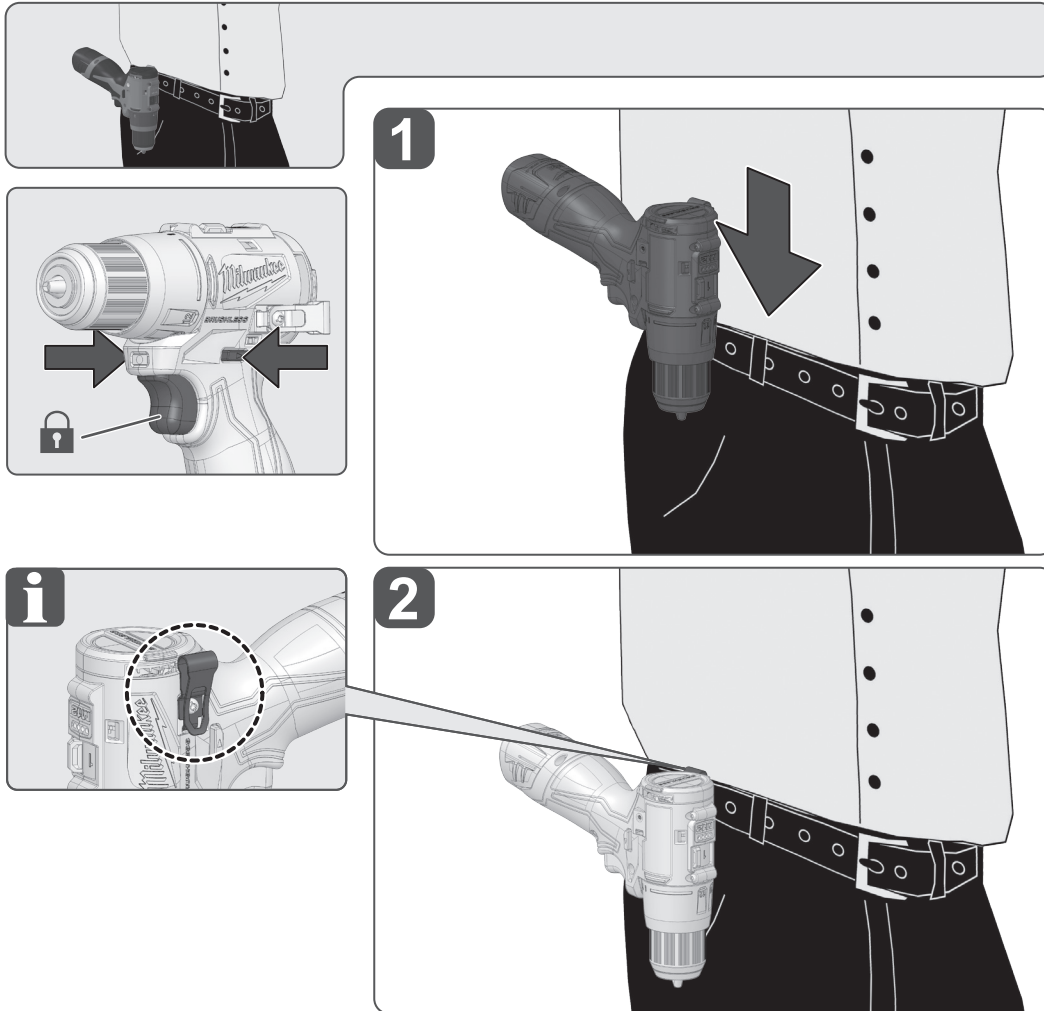

## TECHNICAL DATA

## M12 BLPDRC

Type	Cordless Percussion Drill/Driver
Production code	5054 23 01 XXXXXX MJJJJ
Battery voltage	12 V ---
No-load speed, 1st gear	0–450 min <sup>-1</sup>
No-load speed, 2nd gear	0–1550 min <sup>-1</sup>
Impact range, 1st gear	6750 min <sup>-1</sup>
Impact range, 2nd gear	23250 min <sup>-1</sup>
Torque	40 Nm
Drilling capacity in steel	10 mm
Drilling capacity in wood	
With flat bit	32 mm
With auger bit	10 mm
With hole saw	40 mm
Drilling capacity in brick and tile	10 mm
Wood screws (without pre-drilling)	13 mm
Drill chuck range	1.5–10 mm
Weight according to EPTA-Procedure 01/2014 (2.0–6.0 Ah)	1–1.2 kg
Recommended ambient operating temperature	-18...+50 °C
Recommended battery pack types	M12B..., M12HB...
Recommended chargers	M12-18 C, M12-18 FC, M12-18 AC, M12 C4, C12 C

**Noise information:** Measured values determined according to EN 62841.

Typically, the A-weighted noise levels of the tool are:

Sound pressure level / Uncertainty K	88 dB(A) / 5 dB(A)
Sound power level / Uncertainty K	96 dB(A) / 5 dB(A)

Always wear ear protectors.

**Vibration information:** Total vibration values (vector sum in the three axes) determined according to EN 62841.

Vibration emission value  $a_h$  / Uncertainty K

Impact drilling into concrete	14.0 m/s <sup>2</sup> / 1.5 m/s <sup>2</sup>
Drilling into metal	3.6 m/s <sup>2</sup> / 1.5 m/s <sup>2</sup>
Screwing	1.02 m/s <sup>2</sup> / 1.5 m/s <sup>2</sup>

## ⚠ WARNING!

The vibration and noise emission level given in this information sheet has been measured in accordance with a standardized test given in EN 62841 and may be used to compare one tool with another. It may be used for a preliminary assessment of exposure.

The declared vibration and noise emission level represents the main applications of the tool. However if the tool is used for different applications, with different accessories or poorly maintained, the vibration and noise emission may differ. This may significantly increase the exposure level over the total working period.

An estimation of the level of exposure to vibration and noise should also take into account the times when the tool is switched off or when it is running but not actually doing the job. This may significantly reduce the exposure level over the total working period.

Identify additional safety measures to protect the operator from the effects of vibration and/or noise such as: maintain the tool and the accessories, keep the hands warm, organization of work patterns.

**⚠ WARNING!** Read all safety warnings, instructions, illustrations and specifications provided with this power tool. Failure to follow all instructions listed below may result in electric shock, fire, and/or serious injury.

Save all warnings and instructions for future reference.

### DRILL SAFETY WARNINGS

#### Safety instructions for all operations

**Wear ear protectors when impact drilling.** Exposure to noise can cause hearing loss.

**Brace the tool properly before use.** This tool produces a high output torque and without properly bracing the tool during operation, loss of control may occur resulting in personal injury.

**Hold the power tool by insulated gripping surfaces, when performing an operation where the cutting accessory or fasteners may contact hidden wiring.** Cutting accessory or fasteners contacting a "live" wire may make exposed metal parts of the power tool "live" and could give the operator an electric shock.

#### Safety instructions when using long drill bits

**Never operate at higher speed than the maximum speed rating of the drill bit.** At higher speeds, the bit is likely to bend if allowed to rotate freely without contacting the workpiece, resulting in personal injury.

**Always start drilling at low speed and with the bit tip in contact with the workpiece.** At higher speeds, the bit is likely to bend if allowed to rotate freely without contacting the workpiece, resulting in personal injury.

**Apply pressure only in direct line with the bit and do not apply excessive pressure.** Bits can bend causing breakage or loss of control, resulting in personal injury.

### ADDITIONAL SAFETY AND WORKING INSTRUCTIONS

Use personal protective equipment. Always wear eye protection. The use of protective clothing is recommended, such as dust mask, protective gloves, sturdy non-slip footwear, helmet, and ear defenders.

The dust produced when using the product may be harmful to health. Do not inhale the dust. Wear a suitable dust protection mask.

Remove the battery pack before starting any work on the product.

Clamp the workpiece with a clamping device. Unclamped workpieces can cause severe injury and damage.

Do not machine any materials that present a danger to health, such as asbestos.

Avoid electric cables, gas pipes, and water pipes when working on walls, ceilings, or floors.

Chips and splinters must not be removed while the product is running.

Do not reach into the product while it is running.

Do not insert the bit into the product when the product is running and the trigger is on lock-on status. The bit will spin out of control and may hurt the operator. Make sure that the bit is properly installed before operating the product again.

Do not power on the product again after it has stalled. Powering it on again can cause a kickback with high reaction force. Determine why the product has stalled and rectify it, paying heed to the safety instructions. If necessary, remove the insertion tool.

The possible causes may be:

- The insertion tool is tilted in the workpiece to be machined.
- The insertion tool has pierced through the material to be machined.
- The product is overloaded.

The insertion tool is sharp-edged and can become hot during use.

**⚠ WARNING!** Danger of cuts and burns:

- when changing insertion tools
- when setting the product down

### SPECIFIED CONDITIONS OF USE

The cordless percussive drill/driver is designed for drilling or percussive drilling into concrete and stone, driving screws, and cutting screw threads.

Do not use the product for any other purpose.

### RESIDUAL RISKS

Even when the product is used as prescribed, it is still impossible to completely eliminate certain residual risk factors. The following hazards may arise during use and the operator should pay special attention to avoid:

- injury caused by vibration
  - Hold the product by designated handles and restrict working time and exposure.
- hearing injury caused by exposure to noise
  - Wear ear protection and limit exposure.
- injury due to flying debris
  - Wear eye protection, heavy long trousers, gloves, and substantial footwear at all times.
- health hazards caused by inhalation of toxic dust
  - Wear a suitable dust protection mask.

### BATTERY SAFETY INSTRUCTIONS

#### Use of Li-Ion batteries

Do not dispose of used battery packs in the household refuse or by burning them. MILWAUKEE distributors offer to retrieve old batteries to protect our environment.

Do not store the battery pack together with metal objects (short circuit risk).

Use only M12 System chargers for charging M12 System battery packs. Do not use battery packs from other systems.

Never break open battery packs and chargers, and store them only in dry rooms. Keep battery packs and chargers dry at all times.

Battery acid may leak from damaged batteries under extreme load or extreme temperatures. In case of contact with battery acid, wash it off immediately with soap and water. In case of eye contact, rinse thoroughly for at least 10 minutes and immediately seek medical attention.

No metal parts must be allowed to enter the battery section of the charger (short circuit risk).

Battery packs that have not been used for some time should be recharged before use.

Temperatures in excess of 50 °C (122 °F) reduce the performance of the battery pack. Avoid extended exposure to heat or sunshine (risk of overheating).

The contacts of chargers and battery packs must be kept clean.

For an optimum lifetime, the battery packs have to be fully charged after use.

To obtain the longest possible battery life, remove the battery pack from the charger once it is fully charged.

For battery pack storage longer than 30 days:

- Store the battery pack where the temperature is below 27 °C and away from moisture.
- Store the battery packs in a 30%–50% charged condition.
- Every six months of storage, charge the battery pack as normal.

#### Battery protection for Li-Ion batteries

In extremely high torque, binding, stalling, and short circuit situations that cause high current draw, the product vibrates for about 2 seconds, and then the product powers off. To reset, release the trigger.

Under extreme circumstances, the internal temperature of the battery pack could rise too much. If this happens, the fuel gauge flashes until the battery pack cools down. After the lights go off, continue working.

### Transport of Li-Ion batteries

Lithium-ion batteries are subject to the Dangerous Goods Legislation requirements.

Transportation of those batteries has to be done in accordance with local, national, and international provisions and regulations.

The user can transport the batteries by road without further requirements.

Commercial transport of Lithium-ion batteries by third parties is subject to the Dangerous Goods regulations. Transport preparation and transport are exclusively to be carried out by appropriately trained persons and the process has to be accompanied by corresponding experts.

When transporting batteries:

- Ensure that the battery contact terminals are protected and insulated to prevent short circuit.
- Ensure that the battery pack is secured against movement within the packaging.
- Do not transport batteries that are cracked or leaking.
- Check with the forwarding company for further advice.

**⚠ WARNING!** To reduce the risk of fire, personal injury, and product damage due to a short circuit, never immerse the product, battery pack, or charger in fluid or allow fluid to flow inside them. Corrosive or conductive fluids, such as seawater, certain industrial chemicals, and bleach or bleach-containing products, etc., can cause a short circuit.

### CLEANING

Keep the ventilation slots of the product clear at all times.

Avoid using solvents when cleaning plastic parts. Most plastics are susceptible to various types of commercial solvents and may be damaged by their use. Use clean cloths to remove dirt, carbon dust, etc.









### MAINTENANCE

Use only MILWAUKEE accessories and spare parts. Should components that have not been described need to be replaced, contact one of our MILWAUKEE service agents (see our list of guarantee/service addresses).

If needed, an exploded view of the product can be ordered. State the product type and the serial number printed on the label, and order the drawing at your local service agent or directly at: Techtronic Industries GmbH, Max-Eyth-Straße 10, 71364 Winnenden, Germany.

### SYMBOLS

	Read the instructions carefully before starting the product.
	CAUTION! WARNING! DANGER!
	Remove the battery pack before starting any work on the product.
	Always wear goggles when using the product.
	Wear ear protectors.

	Wear a suitable dust protection mask.
	Wear gloves.
	Do not dispose of waste batteries, waste electrical and electronic equipment as unsorted municipal waste. Waste batteries and waste electrical and electronic equipment must be collected separately. Waste batteries, waste accumulators, and light sources have to be removed from the equipment. Check with your local authority or retailer for recycling advice and collection point. According to local regulations, retailers may have an obligation to take back waste batteries and waste electrical and electronic equipment free of charge. Your contribution to the reuse and recycling of waste batteries and waste electrical and electronic equipment helps to reduce the demand of raw materials. Waste batteries, in particular containing lithium, and waste electrical and electronic equipment contain valuable and recyclable materials, which can adversely impact the environment and the human health if not disposed of in an environmentally compatible manner. Delete personal data from waste equipment, if any.
$n_0$	No-load speed
V	Voltage
	Direct current
	European Conformity Mark
	British Conformity Mark
	Ukraine Conformity Mark
	EurAsian Conformity Mark

#### EC-DECLARATION OF CONFORMITY

We declare as the manufacturer under our sole responsibility that the product described under Technical Data fulfills all the relevant provisions of the following European Directives, European Regulations and harmonised standards.

2011/65/EU (RoHS)  
2014/30/EU  
2006/42/EC

EN 62841-1:2015+A11:2022  
EN 62841-2-1:2018+A11:2019+A1:2022+A12:2022  
EN IEC 63000:2018  
EN IEC 55014-1:2021  
EN IEC 55014-2:2021

Winnenden, 2025-05-13



Martin Landherr  
Managing Director

Authorised to compile the technical file.

#### GB-DECLARATION OF CONFORMITY

We declare as the manufacturer under our sole responsibility that the product described under Technical Data fulfills all the relevant provisions of the following European Directives, European Regulations and harmonised standards.

S.I. 2008/1597 (as amended)  
S.I. 2016/1091 (as amended)  
S.I. 2012/3032 (as amended)

EN 62841-1:2015+A11:2022  
EN 62841-2-1:2018+A11:2019+A1:2022+A12:2022  
EN IEC 63000:2018  
EN IEC 55014-1:2021  
EN IEC 55014-2:2021

Winnenden, 2025-05-13



Martin Landherr  
Managing Director

Authorised to compile the technical file.

Techtronic Industries (UK) Ltd.  
Parkway  
Marlow SL7 1YL  
UK

Copyright 2025  
Techtronic Industries GmbH  
Max-Eyth-Straße 10  
71364 Winnenden  
Germany  
+49 (0) 7195-12-0  
[www.milwaukeeetool.eu](http://www.milwaukeeetool.eu)

Techtronic Industries (UK) Ltd  
Parkway  
Marlow SL7 1YL  
UK

(05.25)  
**4100 4893 15**  
**961015939-01(A)**